

CURRENT STATUS OF THE PROBLEM OF HEAT PUMPS AND REFRIGERATING DEVICES

L. L. Vasiliev

UDC 621.57

In connection with the limited energy reserves in the Republic of Belarus, it is expedient to use sorption heat pumps and refrigerators in heating and refrigeration supply systems. Such heat engines possess a unique capability of utilizing the heat of low-temperature energy sources: water ponds, groundwater, and waste water and steam in combination with traditional heaters of rooms (boilers, furnaces, etc.). Adsorption reversible heat pumps developed at the A. V. Luikov Heat and Mass Transfer Institute of the National Academy of Sciences of Belarus make it possible to obtain 20 to 30 kW/m³ of thermal energy and up to 5 kW/m³ of cold. Such heat pumps save up to 15–20% of primary energy (fuel) for production of electricity, heat, and cold.

Keywords: heat pumps, sorbents, secondary energy resources, evaporators, condensers.

Introduction. It is known that in the Republic of Belarus its GDP's energy intensity, which characterizes the macroeconomic volume of consumed energy resources in tons of oil equivalent per thousand US dollars, is 0.43 in terms of purchasing power parity, whereas in developed European countries it is equal to 0.2 thousand tons of equivalent fuel. To reduce this indicator, one breakthrough direction in the development of Belarusian power engineering can be the development and commercial production of environmentally clean nonelectric heat engines that utilize sorbents. In this connection, it is necessary to implement a program of modernization of the set of boiler plants and industrial furnaces, while adding to them nonelectric sorption heat pumps, which will make it possible to reduce the consumption of primary fuel (gas, mazut, firewood, peat, etc.) by 20–30% while maintaining the same efficiency of power-generating equipment. This modernization will cost significantly less than additional construction of boiler plants and furnaces, since there is no need to carry out capital construction. Heat pumps are placed in already existing spaces occupied by furnace and boiler equipment. The environment (water ponds, soil, groundwater, waste water and steam from industrial production etc.), and also secondary and alternative energy sources, are used as a low-temperature source of energy for such heat pumps. Such devices include heat pumps on solid and liquid sorbents, systems for trigeneration of energy (production of electricity, heat, and cold), air-conditioning systems (including ones for transport, vehicles), and systems for storage and transportation of gas (methane, hydrogen).

The measures provided for by the Montreal and Kyoto Protocols may change the balance of energy technologies currently existing in the world and, in particular, encourage the development and application of nonelectric sorption heat pumps. The work [1] develops a methodology that makes it possible, with account taken of these measures, to perform a comparative analysis of environmental and economic aspects of application of sorption heat pumps and existing heating and cooling systems. This approach, in which use is made of such generalized parameters as total annual energy consumption, mean value of the device efficiency, average energy prices, etc., was applied in [2, 3] with account taken of the specific conditions of Russia and the Republic of Belarus.

The use of sorption heat pumps in the Republic of Belarus will make it possible to substantially increase the efficiency of utilization of natural gas and to ensure its saving. At present, the world demand for heat pumps is basically satisfied by imports from the USA and Japan. Therefore, national programs for production of heat pumps are widely welcomed and encouraged. In Switzerland, 40% of one- and two-department houses are equipped with heat pumps. A similar situation is observed in Austria. Lower-power adsorption heat pumps (zeolites/water; silica gel + salts/water; activated carbons (charcoals) with salt microcrystals/ammonia, etc.) [4–6] are of great interest for single-family houses. One important component of sorption heat pumps is a low-temperature energy source that substantially

A. V. Luikov Heat and Mass Transfer Institute, National Academy of Sciences of Belarus, 15 P. Brovka Str., Minsk, 220072, Belarus; email: Leonard_Vasiliev@rambler.ru. Translated from *Inzhenerno-Fizicheskii Zhurnal*, Vol. 83, No. 4, pp. 763–778, July–August, 2010. Original article submitted December 31, 2009.

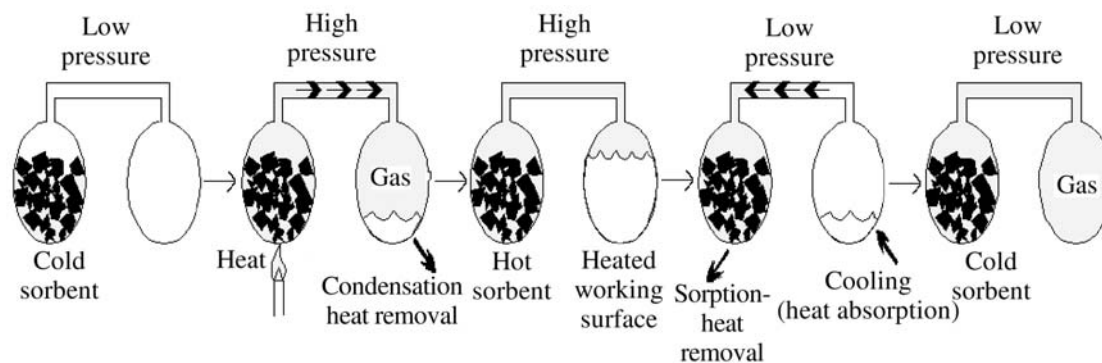

Fig. 1. Principle of operation of the heat pump on solid sorbents.

effects their structure in terms of economy and environmental protection. Hence, the structure of the heat pump depends, to a great extent, on the selected type of the energy source.

One should point out a promising and economically profitable combination of sorption heat pumps with heat exchangers on heat pipes for utilization of the heat of soil, groundwater, rivers and lakes, and rocks [7]. It is obvious that the operating efficiency of a heat pump depends not only on the sorbents' sorbability but also on the level of quality of the heat exchangers (intensification of heat and mass transfer in sorption systems, evaporators, and condensers).

Sorption heat pumps were the subject of the conferences in Paris (1992) [8], Montreal (1997) [9], Munich (1999) [10], Shanghai (2002) [11], Minsk (2003, 2005), and Kyoto (2007) [12].

Thermodynamics and Heat and Mass Exchange in Sorption Heat Pumps. A diagram of a sorption heat pump is shown in Fig. 1.

The simplest version of a heat pump is represented by two closed interconnected vessels. One vessel contains a sorbent saturated with sorbate (working fluid); the other is used as a condenser/evaporator. A vapor of the working fluid is desorbed in heating of the sorbent; the temperature and pressure in the vessel increase and the vapor is transferred to the condenser where it subsequently condenses. Heat is transferred to the ambient medium through a vessel wall. This process continues until the pressure in the two vessels is equalized. The inverse cycle of transfer of the working medium begins, once the temperature and pressure in the first vessel are reduced to a value at which the pressure in the second vessel begins to exceed that in the first vessel. The process of adsorption of the working-fluid vapor by the sorbent begins (the sorbent operates as a pump); in the second vessel, the working fluid starts to boil (evaporates) with absorption of the latent heat of vaporization. The walls of the second vessel cool down. In vapor adsorption by the sorbent, in the first vessel the process is accompanied by the release of sorption heat. The operating cycle of the sorption heat pump is completed.

Sorption apparatuses may include sorption heat pumps, chemical heat pumps, and sorption heat pumps with a complex sorbent (adsorber + chemical substance, e.g., activated carbon (charcoal) saturated with salt microcrystals). Chemical heat pumps in pure form are inefficient, since the salt crystals are nodulized into a polycrystal in pump operation and the surface for mass exchange sharply diminishes compared to the classical sorption heat pumps. A combination in the form of salt microcrystals on the surface of a porous body, e.g., carbon fiber, or a porous matrix (complex sorbent) is efficient.

One currently uses two types of thermally-driven sorption heat pumps of practical interest:

- (1) absorption heat pumps with liquid sorbents (ammonia/water, lithium bromide/water) and
- (2) adsorption heat pumps with solid sorbents.

Both absorption and adsorption heat pumps have their advantages and drawbacks. Common to them is the thermal drive (flame, hot gas, water, solar energy, etc.): they do not require electric compressors for generation of heat and cold. Sorption heat pumps are characterized by the presence of an evaporator, a condenser, an adsorber (absorber), and a desorber. There are three possibilities of utilizing sorbents in sorption heat engines:

- (1) heat pipe/refrigerator (cooler) with an evaporator, a condenser (L/G saturation line), and reactor S; its efficiency for heating purposes is determined as

$$\text{COA} = 1 + \frac{\Delta H_c}{\Delta H_R}, \quad (1)$$

(2) sorption refrigerator for production of cold

$$\text{COP} = \frac{\Delta H_e}{\Delta H_R}, \quad (2)$$

(3) sorption reversible heat pump for simultaneous heating and cooling

$$\text{COPA} = \frac{\Delta H_e + \Delta H_c + \Delta H_R}{\Delta H_R}. \quad (3)$$

A thermal transformer with adsorber S and an evaporator/condenser is of interest in some cases. The efficiency of such a transformer is determined as $\text{COA}_e = \frac{\Delta H_R}{\Delta H_R + \Delta H_e}$; it is less than unity but makes it possible to substantially raise the potential (temperature) of the heat source. Also, there is a heat pump/transformer with two adsorbers S_1 and S_2 . The efficiency of such a heat pump is equal to $\text{COA} = 1 + \frac{\Delta H_{R1}}{\Delta H_{R2}}$. The efficiency of the thermal

transformer is accordingly equal to $\text{COA}_R = \frac{\Delta H_{R1}}{\Delta H_{R1} + \Delta H_{R2}}$. Unlike the previous versions of a heat pump, in the present heat pump/transformer, the working medium is gas (superheated steam). Among these heat engines are heat pumps with hydrogen or ammonia, water, and those operating on a gaseous working medium.

Let us consider the possibilities of using sorption heat engines. A classical heat engine consumes the heat Q_1 from a thermostat with a high temperature T_1 , gives the heat Q_2 to a thermostat with a low temperature T_2 , and does the work $Q_1 - Q_2 = Q_1 \left(1 - \frac{T_2}{T_1}\right)$. A sorption heat pump uses and generates only thermal energy and operates in the simplest case between three thermostats at high (T_g), intermediate (T_c), and low (T_e) temperatures; it can convert thermal energy operating in three regimes, namely, the regime of cooling, heating, and increase in the temperature potential.

In the *regeneration step* common to these regimes, the heat from the external source at the temperature T_g is supplied to a reactor connected to the condenser at the temperature $T_c < T_g$. The equilibrium pressure of the working substance in the reactor is infinitesimally higher than that in the condenser; therefore, the volatile component formed in the reactor in desorption is transferred to the condenser where it condenses at the temperature T_c . The heat ΔH is absorbed in the reactor; the heat ΔH_e , which is either used for heating (heater regime) or diffuses into the environment (refrigerator regime), is released in the condenser.

In the *refrigerator regime*, the environment is the thermostat at the temperature T_c , whereas the temperature T_e is the required temperature of the refrigerator, i.e., the temperature at which heat is taken from the user's device. The equilibrium pressure of the working substance in the evaporator at the temperature T_e is infinitesimally higher than that in the reactor at the temperature T_c ; therefore, the evaporated working substance is transferred to the reactor where the process of sorption of the working medium (ammonia, CO_2 , water, hydrogen) occurs. The heat of its formation ΔH diffuses into the environment, whereas the heat ΔH_e taken from the user's device is absorbed in the evaporator, producing the cooling effect. The efficiency or the coefficient of performance of a refrigerating machine are calculated as

$$\eta_{\text{refr}} = \frac{\Delta H_e}{\Delta H}. \quad (4)$$

The system reverts to the original (pre-regeneration) state.

In the *heater regime*, the thermostat at the temperature T_e is the environment, whereas the temperature T_c at which heat is transferred to the consumer must correspond to heating (usually $T_c \geq 40^\circ\text{C}$). The equilibrium pressure of the working medium in the evaporator at the temperature T_e is infinitesimally higher than the pressure in the reactor at the temperature T_c ; therefore, a given compound formed in evaporation is transferred to the reactor where it is sorbed with a sorbent. The heat ΔH_e taken from the environment is absorbed in the evaporator, and the heat ΔH used for heating is released in the reactor. A result of this step is "pumping" of heat from the medium with a low temperature T_e at which the heat can be consumed without loss to the reactor with a higher temperature T_c . The system reverts to the original state. The heat release in the reactor and the condenser is used for heating, whereas the efficiency (gain) is found as

$$\eta_{\text{heat}} = \frac{\Delta H_e + \Delta H}{\Delta H} = 1 + \eta_{\text{refr}} > 1. \quad (5)$$

In this case heat is absorbed in an equilibrium manner at T_c , and the useful heat ΔH is released during the sorption reaction at a high temperature T_g with an efficiency

$$\eta_{\text{t.p}} = \frac{\Delta H}{\Delta H_e + \Delta H} < 1. \quad (6)$$

In calculating the efficiency of the heat engine, we have made the ordinary assumption that the expenditure of heat on changing the system's heat capacity is equal to zero, i.e., we either disregard the thermal mass of the system or assume the efficient heat recuperation in it. Even if the recuperation is incomplete or entirely absent, the expenditure on heating the system is usually small compared to the sorption heat; therefore, the approximation used is justified in this case, too.

The maximum theoretical efficiency of the heat engine operating between three thermostats with temperatures T_e , T_c , and T_g is

$$\eta_{\text{refr}} = \frac{\frac{1}{T_c} - \frac{1}{T_g}}{\frac{1}{T_e} - \frac{1}{T_c}} \quad (7)$$

for refrigerating and

$$\eta_{\text{heat}} = \frac{\frac{1}{T_e} - \frac{1}{T_g}}{\frac{1}{T_e} - \frac{1}{T_c}}. \quad (8)$$

for heating. Hence we can also obtain the efficiency for the regime of increase in the temperature potential (heat transformation to a temperature level higher than the heater temperature)

$$\eta_{\text{t.p}} = \frac{\frac{1}{T_e} - \frac{1}{T_c}}{\frac{1}{T_e} - \frac{1}{T_g}}. \quad (9)$$

Thus, the general thermodynamic analysis of three-temperature thermal cycles leads to expressions (7)–(9) in which the efficiency is a function of three temperatures of the cycle and is independent of the characteristics of the sorbent–sorbate working pair.

The second most important characteristic of sorption heat pumps is the specific power W_{sp} , i.e., the ratio of the power W absorbed in the evaporator (for cooling) or released in the condenser and adsorber (for heating) to the sorbent mass m (or volume V):

$$W_{sp} = \frac{W}{m} \quad \text{or} \quad W_{sp} = \frac{W}{V}. \quad (10)$$

This quantity is also dependent on the thermodynamic characteristics of the sorption reaction, such as the amount of sorbate exchanged in the cycle and on the dynamic parameters of the device, primarily the cycle time. This time in turn is determined by the intensity of the interrelated heat- and mass-transfer processes; the quantity W_{sp} can be of paramount importance for using sorption heat pumps in air-conditioning systems in a car or a locomotive cabin, producing ice on fishing vessels, and other purposes. In all these cases low-temperature heat from the engine's cooling system is excessive; therefore, the efficiency of its utilization for production of cold (COP) is of no critical importance. Obtaining a high specific power becomes the prime objective, since the space for placement of a refrigerating device is limited.

Water, ammonia, and methanol are usually used as sorbates in sorption heat engines. The basic advantages of water are the high evaporation heat and environmental purity, whereas the drawbacks are low pressure of the steam and high freezing point, which substantially retard the sorption/desorption dynamics; this imposes substantial restrictions on the specific power and dimensions of the device. Furthermore, in this case requirements on the system's airtightness become stricter and the influence of even a small amount of residual gases can be substantial. Freezing at 0°C makes it impossible to use this sorbate at low temperatures.

Ammonia has a low freezing point and a high pressure; however its evaporation heat is lower than that of water; methanol is characterized by intermediate values of these characteristics. Water is usually used in air-conditioning systems ($T_e = 5\text{--}15^\circ\text{C}$), methanol is used for air-conditioning and production of ice ($T_e = -5\text{--}0^\circ\text{C}$), whereas ammonia is also used for deep freezing.

Once the sorbate and the cycle are determined, it is necessary to select a sorbent optimum for the prescribed cycle. One currently uses as working pairs:

- (a) ammonia/water and water/lithium bromide for absorption heat engines (AbHEs) and
- (b) zeolite/water, silica gel/water, carbon/methane and carbon/ammonia, and carbon + salt microcrystals/ammonia for adsorption heat engines (AdHEs).

In absorption heat pumps, one uses the phenomenon of absorption of the vapors of low-temperature liquids by the films of high-temperature liquids. The $\text{H}_2\text{O}/\text{LiBr}$ pair used in air-conditioning systems and the $\text{NH}_3/\text{H}_2\text{O}$ pair used in refrigerators have enjoyed the widest practical application. However, we know of publications in which new pairs of working fluids, i.e., organic heat-transfer agents, have been described [13–15]. The main advantage of absorption heat pumps over adsorption heat pumps is organization of a (time-)constant sorption/desorption process, which improves the thermodynamic operating efficiency (COP) of a heat pump. A drawback of absorption heat pumps is their sensitivity to the influence of gravity, the necessity of using electric pumps for pumping of the liquid, and the phenomenon of crystallization of an aqueous solution of LiBr at elevated temperatures.

In absorption heat pumps, the emphasis is on the heat exchange of the films of the solution of salts in a liquid $\text{LiBr}/\text{H}_2\text{O}$ (or of a liquid in a liquid $\text{NH}_3/\text{H}_2\text{O}$) with a hot wall (desorption) and a cold wall (absorption). The $\text{NH}_3/\text{H}_2\text{O}$ pair is characterized by the ammonia desorption in heating of the solution. The ammonia vapor condenses in the heat-pump's condenser, and the liquid enters the evaporator where it evaporates. Cooling of the depleted aqueous solution of ammonia creates favorable conditions for the absorption of the ammonia vapor by the cooled liquid. Both processes are accompanied by thermal effects (heat absorption/heat release). The process of heat and mass exchange in absorption of the ammonia vapor by water can be intensified with special additives that decrease the surface tension of water [16]. Since an aqueous solution of salt $\text{H}_2\text{O}/\text{LiBr}$ is the most widely used in commercially manufactured heat pumps, many publications have been devoted to investigation of the influence of surfactants on the intensification of the steam adsorption by the solution [17]. No doubt, the viscosity of the liquid and its surface tension exert a substantial influence on the hydrodynamic of flowing-down films. The concentration and temperature gradients in the process of absorption of the steam by the enriched solution accelerate the mixing of liquid layers in the film and intensify heat exchange. Accordingly the presence of surfactants in the films on the hot heat-exchange surface (desorption) retards the process of heat and mass exchange [18]. The method of utilizing the heat of a generator (high-temperature heat exchanger) for pre-heating of an absorber (low-temperature heat exchanger) is widely practiced in heat pumps on liquid sorbents. Such a method of utilization of heat is called GAX (Generator-Absorber Heat Exchange) [17–19].

1.1. *Adsorption Heat Pumps.* The principle of operation of adsorption heat pumps is based on the capability of solid bodies (sorbents) to adsorb a liquid vapor [3, 5]. Activated carbons, zeolites, and silica gels have enjoyed the widest application as sorbents for air-conditioning and ventilation systems [20]. In recent years, the possibilities of using silica gels in combination with metal salts [21], sorption heat pumps with a complex sorbent, have been considered. In creating heat pumps, of great interest are activated carbon and ammonia [22] as well as activated carbon fiber and ammonia [23] and zeolite and water. To calculate the sorbate/sorbent pair in the heat pump we must know the following parameters:

- (1) sorbability (found in accordance with the Dubinin–Radushkevich equation) at $p_{\text{sat}}(T, w)$;
- (2) properties of the liquid: $\rho_{\text{liq}}, c_{\text{liq}}, c_{\text{st}}, p_{\text{sat}}(T)$, an ideal gas;
- (3) sorption heat:

$$q_{\text{ads}}(T, w) = -r^* \left[\frac{\partial \ln(p_{\text{sat}})}{\partial(1/T)} \right]_{p,w};$$

- (4) heat capacity:

$$\left[\frac{\partial c_{p,w}}{\partial w} \right]_{p,T} = - \left[\frac{\partial r_{p,T}^*}{\partial T} \right]_{p,w} = c_{p,v} - c_{p,\text{liq}}^{\text{ads}};$$

- (5) enthalpy h_{ads} ;
- (6) entropy $S_{\text{ads}}(T, w)$.

The simplest heat pump incorporates one adsorber, an evaporator, a condenser, and valves. Its operating efficiency (cooling performance COP) is dependent on the structural features and the selected pair "sorbate (liquid)/sorbent (solid body):"

$$\text{COP} = \frac{r^* \Delta m}{\Delta m \Delta H + \Sigma m c_p \Delta T} < \frac{r^*}{\Delta H},$$

where $\frac{r^*}{\Delta H}$ is the efficiency of the Carnot cycle for the prescribed sorbate/sorbent pair.

The structure of a pump (heat capacity of metallic elements) substantially influences its efficiency. The lower the heat capacity of metallic components and the temperature difference between the evaporator and the condenser, the higher the COP.

The advantage of adsorption heat pumps over absorption ones is the possibility of using them in a wide temperature range and insensitivity to the gravitational field (which is particularly important when heat pumps are installed on transport vehicles).

A drawback of adsorption heat pumps is periodicity of their operation (process of heating/cooling of the sorbent), leading to the expenditure of additional energy on heating and cooling not only the sorbent but the adsorber casing as well. The low thermal conductivity of a porous material retards the process of nonstationary heating/cooling, increases the cycle time, and diminishes the heat-pump COP. The use of the method of convective heating/cooling of the sorbent accelerates the cycle in the heat pump and solves this problem.

The process of intensification of heat and mass exchange in solid-sorbent heat pumps is more critical than that in an absorption pump, since the thickness of a sorbent layer is larger than the thickness of a liquid film. The effective thermal conductivity of the layer of porous sorbent is low and must be increased by adding high-thermal-conductivity materials (e.g., a foam metal) [24–26]. In solid-sorbent heat pumps, the process of heat and mass exchange of the sorbent and of heat exchange between the sorbent and the heat-exchanger wall is of importance. Intensification of heat exchange, along with the increase in the sorbability of the sorbent and the kinetics and dynamics of mass exchange, is a necessary requirement for improving the operating efficiency of a heat pump.

In modeling heat and mass exchange in a solid-sorbent adsorber, one primarily considers the equations of heat balance in the working fluid (heat exchanger), the adsorber casing, and the sorbent. The kinetic equations of mass ex-

change of the sorbent with the sorbate are additionally considered. In considering the problem, one makes the following assumptions:

- (a) pressure in the sorbent is constant;
- (b) the solid phase and the working medium in the sorbent are in thermodynamic equilibrium;
- (c) the sorbate (gas) is ideal;
- (d) the thermal resistance of the adsorber wall is negligible;
- (e) heat loss is small;
- (f) the sorbent is isotropic and of uniform porosity.

1.2. *Equations Characterizing Heat Exchange.* The heat-balance equation for the working fluid is

$$\frac{\partial T_{\text{liq}}}{\partial t} + v \frac{\partial T_{\text{liq}}}{\partial z} - D_{\text{liq}} \frac{\partial^2 T_{\text{liq}}}{\partial z^2} + \frac{h_{\text{liq}} S_{\text{liq}}}{V_{\text{liq}} \rho_{\text{liq}} c_{p,\text{liq}}} (T_{\text{liq}} - T_t) = 0, \quad (11)$$

where v , ρ_{liq} , V_{liq} , and $c_{p,\text{liq}}$ are respectively the velocity, density, volume, and specific heat of the working fluid of the heat exchanger, D_{liq} is the thermal diffusivity of the fluid, T_{liq} is the temperature of the working fluid, T_t is the wall temperature of the tubular heat exchanger, and h_{liq} and S_{liq} are the coefficient of heat exchange and the surface area of heat exchange between the fluid and the tube.

The heat balance in the heat-exchanger tube can be written as

$$\rho_t V_t c_{p,t} \frac{\partial T_t}{\partial t} + h_{\text{liq}} S_{\text{liq}} (T_t - T_{\text{liq}}) + h_s S_s (T_t - T_s) = 0, \quad (12)$$

where V_t , ρ_t and $c_{p,t}$ are respectively the volume, density, and specific heat of the tube, T_t is the tube-wall temperature, T_s is the sorbent temperature at the sorbent/tube boundary, and h_s and S_s are respectively the heat-transfer coefficient and the surface area of the tube/adsorber boundary.

The heat-balance equation for the sorbent can be written as

$$(\rho_s c_{p,s} + \bar{q} c_{p,a}) \frac{\partial T_s}{\partial t} - \Delta H \frac{\partial \bar{q}}{\partial t} = \frac{\lambda_s}{r} \frac{\partial}{\partial r} \left(r \frac{\partial T_s}{\partial r} \right), \quad (13)$$

where ρ_s is the density of the sorbent, $c_{p,s}$ and $c_{p,a}$ are the specific heats of the sorbent and the sorbate, λ_s is the thermal conductivity of the sorbent, ΔH is the adsorption heat, and \bar{q} is the average amount of the adsorbed gas on the surface with a radius r .

The heat supplied to the adsorber via the heat exchanger is equal to

$$H_{S1} = \int_0^{t_c/2} m_{\text{liq}} c_{p,\text{liq}} (T_h - T_{\text{eff1}}) dt. \quad (14)$$

The heat generated on the heater is

$$H_{S2} = \int_0^{t_c/2} m_{\text{liq}} c_{p,\text{liq}} (T_h - T_{\text{eff2}}) dt. \quad (15)$$

The heat-regeneration coefficient (efficiency of the device) r_g is determined as the ratio of the heat difference between the hot adsorber and the heat of the heater to the heat of the hot adsorber

$$r_g = \frac{H_{S1} - H_{S2}}{H_{S1}} = \int_0^{t_c/2} \frac{T_{\text{eff2}} - T_{\text{eff1}}}{T_h - T_{\text{eff1}}} dt. \quad (16)$$

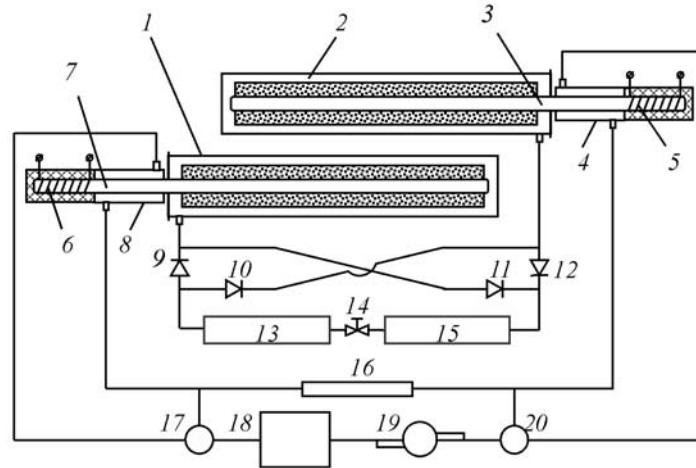

Fig. 2. Schematic diagram of the adsorption heat pump with a thermal-regulation system on heat pipes: 1 and 2) sorbent-filled adsorbers; 3) condenser; 4) evaporator; 5–8) valves; 9 and 10) liquid-type heat exchangers; 11 and 12) heaters; 13 and 14) heat pipes; 15) controlled throttle; 16 and 17) three-way valves; 18) liquid-type pump; 19) rotameter; 20) thermostat.

The efficiency of the cooling cycle without heat regeneration and with regeneration of the adsorber heat is determined as

$$\text{COP}_{\text{wth r}} = \frac{\Delta Q E_{\text{ev}}}{H_{S1}}, \quad (17)$$

$$\text{COP} = \frac{\Delta Q E_{\text{ev}}}{H_{S2}} = \frac{\text{COP}_{\text{wth r}}}{1 - r_g}, \quad (18)$$

where $E_{\text{ev}} = L_u(T_{\text{ev}}) - c_{p,a}(T_c - T_{\text{ev}})$.

The parameter characterizing the operating efficiency of the adsorption heat pump is the specific cooling power determined as

$$\text{SCP} = \frac{\Delta Q E_{\text{ev}}}{t_{\text{cycle}} m}. \quad (19)$$

Mass exchange between the gas working fluid (sorbate) and the sorbent can be described using the equilibrium-state model. The process of mass exchange between sorbent particles is assumed to be quite rapid in the absence of a concentration gradient in the sorbent. The gas phase and the solid body (particles) are in thermodynamic equilibrium. The mass of the adsorbate (adsorbed gas) in the sorbent is dependent only on the pressure and temperature in the adsorber, i.e., the equilibrium-adsorption equation, $q^* = f(T, P)$, holds true:

$$\frac{\partial \bar{q}}{\partial t} = \frac{\partial q^*}{\partial t}. \quad (20)$$

Examples of numerical calculation of the process of heat and mass exchange in the adsorber and the heat exchanger have been given in [12, 17, 18, 27, 28].

2. Practical Applications of Sorption Heat Pumps. Several variants of utilization of the heat of high-temperature adsorbers for pre-heating of low-temperature adsorbers have been proposed recently with the aim of intensifying heat and mass exchange in the adsorbers and of raising the operating efficiency of heat pumps. The heat is utilized directly with heat exchangers (heat pipes) or by mass exchange between adsorbers [27–30]. Thus, sorption reversible

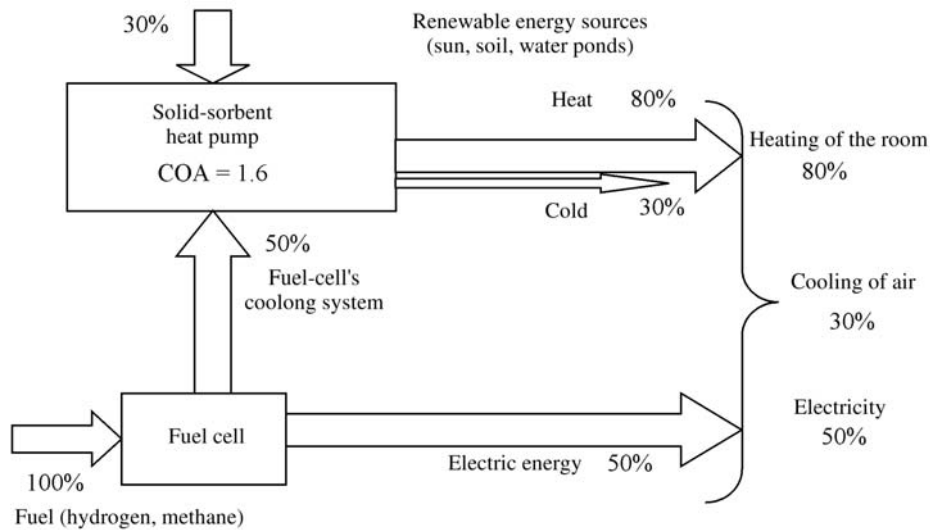

Fig. 3. Diagram of trigeneration of energy (electricity, heat, and cold) which is based on a fuel cell and a sorption heat pump and in which 50% of the fuel-cell energy is converted to electricity and 50%, to heat. Thermal energy is used for activation of the sorption heat pump; 80% of the heat-pump thermal energy is used for heating and 30% of the energy is used for cooling (30% of energy is supplied to the pump from the environment).

heat pumps developed at the Heat and Mass Transfer Institute of the National Academy of Sciences of Belarus make it possible to obtain 20 kW/m^3 of thermal energy and 5 kW of cold. Such heat pumps save up to 15–20% of primary energy (fuel) for production of electricity, heat, and cold (Fig. 2). They can profitably (in energy terms) be used in systems for cogeneration and trigeneration of energy in combination with motor generators, high-temperature and low-temperature fuel cells, and photoelectric energy converters. These power plants, widespread in Europe, save up to $50 \cdot 10^9 \text{ GJ}$ of energy, which is equivalent to $1.6 \cdot 10^9 \text{ m}^3$ of natural gas (300 million euros). Less carbon dioxide ($3 \cdot 10^7$ tons) escapes into the environment. The most important prerequisite for intense development of heat pumps worldwide is support from the state. In many developed countries, there are state foundations and programs stimulating energy savings at energy-intensive enterprises.

One example of such support is Denmark's established practice of reducing taxes (mainly through a reduction of tax components in tariffs on energy resources consumed) for companies that conduct regular energy audits and continuous monitoring of energy consumption and that implement all energy-saving measures recommended by auditors with a payback period of less than 4 years. Moreover, in this case companies can count on state subsidies of up to 30% of the expenses incurred during the conduct of energy surveys. In Germany, state organs facilitate the purchase, assembly, and commissioning of improved heat-pump installations for heating rooms and heating water for daily-life purposes that are manufactured commercially and are available for sale in a specialized trade network. The great prospects for utilizing released heat in modern fuel cells (especially, high-temperature ones) make it possible to hope for wide use of fuel cells instead of steam turbines and electric generators at thermal electric power stations. The use of sorption heat pumps makes it possible to utilize the heat from the cooling system of fuel cells; at the same time, the operating efficiency of the fuel cell itself increases. It is known that, in generating 25 kW of electricity, the fuel cell releases up to 36 kW of heat. Fuel cells need cooling, since the temperature of the cell affects the intensity of the catalytic reaction, the release of moisture in the cell, and the dehydration of the membranes. Adsorption heat pumps combined with fuel cells or internal combustion engines are of interest for application in transport vehicles. The SO-COOL project oriented to the creation of energy-trigeneration systems (electricity, heat, and cold) that are used in daily life has been implemented in the course of the fifth framework EU F5 Energie program carried out in the European Community. A rise of 15–20% in the efficiency of such installations occurs due to the utilization of the heat of waste gases and discharge liquid of diesel generators or Stirling engines for generating cold with the involvement of sorption technologies (Fig. 3).



Fig. 4. Sorption heat pump for heating of air and cooling of water of power 4 kW (heat) and 1 kW (cold), designed at the Heat and Mass Transfer Institute of the National Academy of Sciences of Belarus.

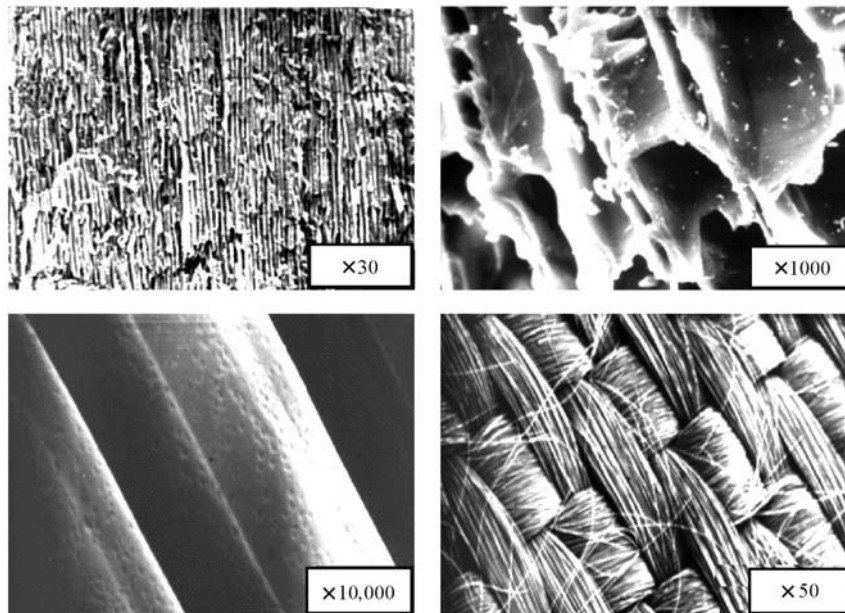

Fig. 5. Samples of a carbon sorbent for the heat pump. Top, activated charcoal, bottom, activated carbon fiber.

New-type sorption heat pumps and refrigerators must be inexpensive and have a high thermodynamic efficiency, reliability, and durability. With this aim in mind one must intensify the process of heat and mass exchange in a porous sorbent and the heat exchange of the sorbent with the adsorber wall and the environment. It is necessary to raise, in the nearest future, the density of energy storage in a solid sorbent from 10 kW/m^3 to $20\text{--}30 \text{ kW/m}^3$, simultaneously increasing the cooling power of a small-scale refrigerating device. With orientation to the use of diesel-generator sets, one can utilize both the heat of waste gases and of the cooling liquid. For this purpose one uses high-pressure sorption technologies (activated carbon/ammonia) (low-pressure sorption technologies (silica gel-water) in the case of orientation to the cooling-liquid heat). Sorption technologies are noiseless, since there is no mechanical compressor. Environmentally hazardous coolants (CFC, HCFC, HFC) are not used in them. Solid-sorbent sorption re-

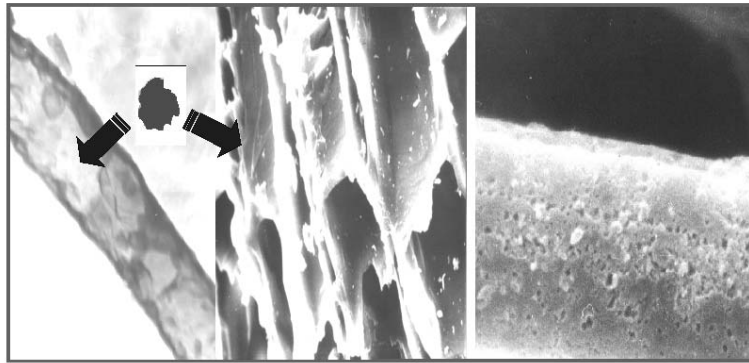

Fig. 6. Samples of a composite sorbent (the arrows indicate salt microcrystals on carbon fiber). $\times 10,000$.

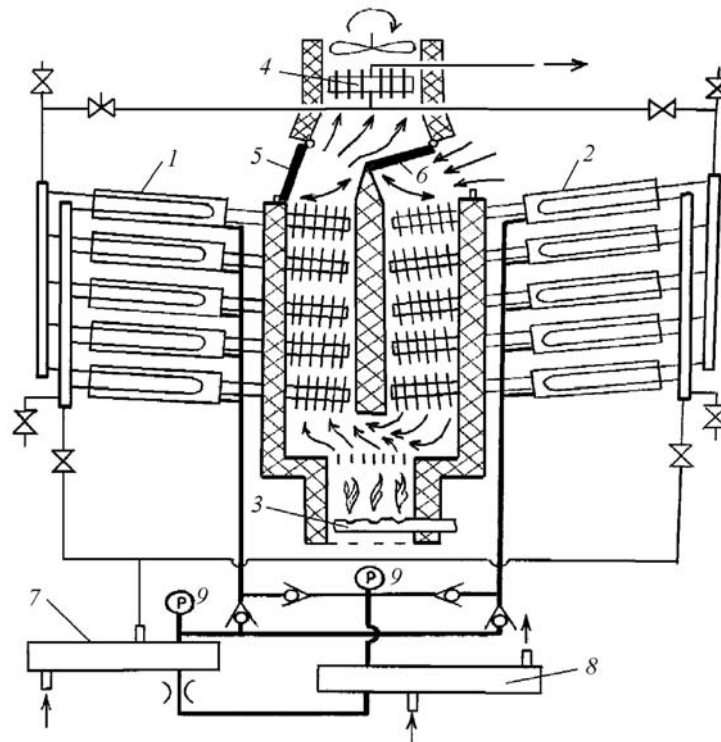

Fig. 7. Sorption heat pump (designed at the Heat and Mass Transfer Institute of the National Academy of Sciences of Belarus) for production of superheated steam and hot and cold water ($5-10^{\circ}\text{C}$): 1 and 2) adsorbers; 3) gas burner; 4) boiler; 5 and 6) bypass gas valves; 7) evaporator; 8) condenser; 9) manometer.

frigerators with a refrigerating capacity of more than 100 kW have been developed in some countries of the world and are commercially produced.

New developments of miniature refrigerating machines and heat pumps efficient for agricultural application have been carried out at the Heat and Mass Transfer Institute of the National Academy of Sciences of Belarus. Figure 4 gives a photograph of a sorption heat pump developed at the Heat and Mass Transfer Institute of the National Academy of Sciences of Belarus and intended to heat air and to cool water. The pump consists of four adsorbers filled with composite sorbent (CaCl_2 microcrystals on the active-carbon surface). The evaporator of the heat pump is used for cooling of water. The pump's condenser and finned adsorbers are intended to heat air in the room. The scientific and technical bases of the heat-pump structure are innovation solutions: selection of an efficient sorbent/sorbate pair,



a

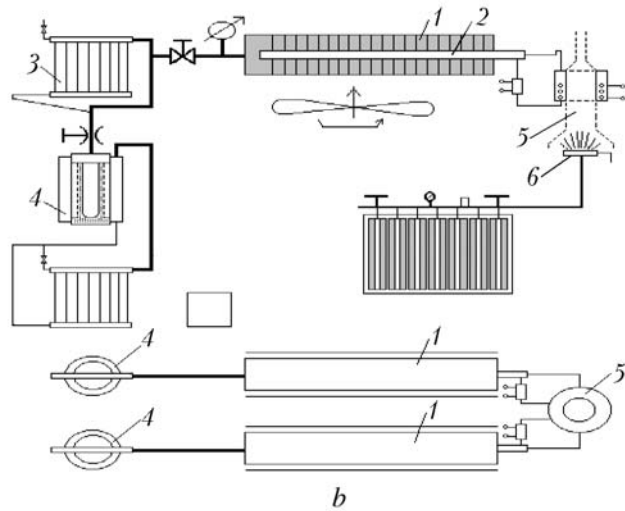

b

Fig. 8. External view (a) and the diagram (b) of a two-stroke sorption heat pump: 1 and 2) adsorbers; 3) condenser; 4) evaporator; 5) heat pipe; 6) gas burner.

intensification of the process of heat and mass exchange in the sorbent and of the sorbent with the adsorber wall, increase in the specific heat of the sorbent, etc. A long service life of a heat pump requires that a number of problems, i.e., those of compatibility of materials and heat-transfer agents and the absence of noncondensable gases in the refrigerating machine, be solved. For the high density of the stored energy and thermodynamic efficiency of the heat pump to be ensured, the sorbent must be inexpensive and nontoxic, have a large sorption heat, and be noncombustible and environmentally clean. As a sorbent one predominantly uses activated carbons, silica gels, zeolites, metal salts, and compositions of the above materials. Typical specimens of carbon sorbents and composites (salt microcrystals on a fiber) are shown in Figs. 5 and 6.

The source of thermal energy for the pump (Fig. 7) is a gas burner (waste gases of the motor-generator). When a gas burner is used, heating of the adsorbers and desorption of the sorbent occur. Simultaneously the waste gases heat water in the waste heat exchanger from 12 to 60–70°C; here, 5 kW of thermal energy is generated. Bypass gas valves make it possible to organize the cooling–heating cycle of the adsorbers due to the periodic supply of cold air and hot gases from the burner (internal combustion engine) alternatively. The cold and hot gases are necessary for adsorbing and desorbing the sorbent in the adsorbers. Owing to the adsorber operation, the water in the liquid circuit is cooled down to a temperature of 3–5°C and 1 kW of cold is generated. Such a plant is suitable for cooling of milk on farms.

Adsorption heat engines have only begun to appear on the market of energy-saving technologies at present. It is only adsorption water chillers based on the working pair "silica gel Fuji RD–water" and produced by Nishiyodo Kuchouki Co. Ltd, Japan since 1986 that have been commercially available until recently. The projected payback of these devices is 2–3 years. Another company manufacturing commercial adsorption water chillers is Micon Co. Ltd. (Japan). In these devices, hot water at $T_g = 75^\circ\text{C}$ is used and cold water at $T_e = 9^\circ\text{C}$ is produced for air-conditioning purposes; for these conditions, the COP is equal to 0.6. Both types of AdHEs are sold on the US, Canadian, and European markets. Their power is 0.1–0.5 MW.

For one-family houses, low-power adsorption heat pumps are of great interest. Prototypes of these devices of power about 5–10 kW or more are being tested in China, Germany, The Netherlands, Italy, Great Britain, Austria, Spain, and other countries. In the recent years, several European companies (SolarNext, Viallant, SorTech AG, and others) have simultaneously offered AdHEs of power 5–20 kW that utilize heat waste with a temperature of 60–100°C for regeneration of the adsorbent, solar water and air heaters, or the heat of combustion of natural gas. Also, devices for utilization of the heat of automobile engines with the aim of using it for air-conditioning of the cabin are being intensely developed.

Figure 8 shows the diagram of a sorption heat pump with external and internal recovery. Owing to this, the operating efficiency of the pump (COP) attains a value of 1.62; its refrigerating capacity is equal to 0.6.

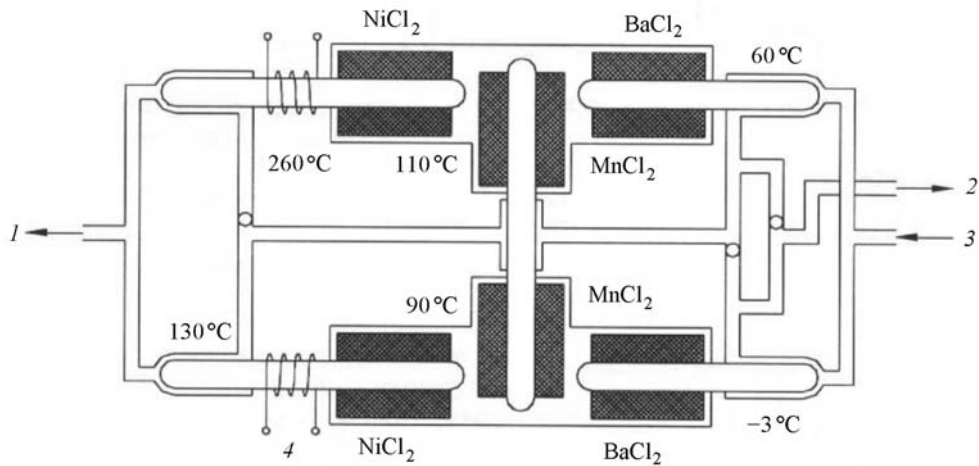

Fig. 9. Sorption heat pump: 1) escape of the superheated steam; 2) egress of cold water; 3) inlet of water of room temperature; 4) heat supply.

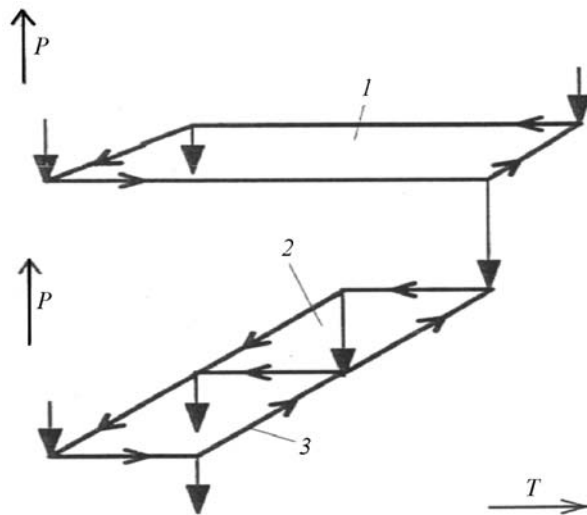

Fig. 10. Three-cascade heat pump: 1) high-temperature adsorber ($\text{NiCl}_2/\text{NH}_3$), 2) moderate-temperature adsorber ($\text{MgCl}_2/\text{NH}_3$), 3) low-temperature absorber on liquid sorbent (LiBr/water).

To further improve the efficiency of heat pumps on solid and liquid sorbents and to adapt them to high-temperature heat engines, it is expedient to use the so-called two- and three-cascade thermodynamic cycles.

For example, the waste heat of high-temperature fuel cells is conveniently utilized using adsorption heat pumps in series with low-temperature absorption heat pumps (LiBr -water). The waste gases of heat engines (high-temperature fuel elements) having a high temperature ($600\text{--}800^\circ\text{C}$) are connected, via the heat exchanger, to adsorption heat pumps filled with high-temperature sorbents (NiCl_2), and the pump's working substance is desorbed (Fig. 9). The temperature of the waste gas of the heat engine decreases to $300\text{--}400^\circ\text{C}$. The gas is fed to the moderate-temperature adsorber (MgCl_2), and the process of desorption of the working substance occurs again. Finally, the cooled gas enters the low-temperature absorber containing an LiBr -water pair where the steam is desorbed from the brine. Figures 10 and 11 show the Clausius-Clapeyron diagram for this version of a heat engine and the diagram of a three-cascade heat pump.

Wide prospects for utilizing the released heat in today's fuel cells (particularly high-temperature ones) give us a hope that these cells will enjoy wide acceptance at thermal electric power stations instead of steam turbines and electric generators.

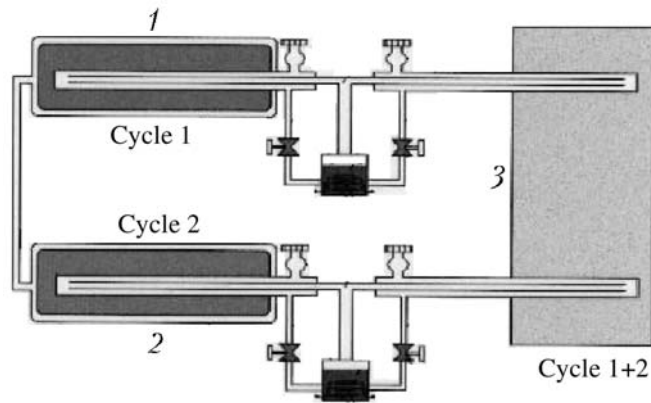

Fig. 11. Three-cascade sorption heat pump with internal regeneration: 1) high-temperature adsorber; 2) moderate-temperature adsorber; 3) low-temperature adsorber on liquid sorbent (LiBr/water).

It should be noted that the use of sorption engines is particularly expedient in the presence of a relatively inexpensive heat source for regeneration of the sorbent (low- and high-pressure vapors or a liquid from the cooling system of different engines, turbines, or technological processes, exhaust gases, etc.). Also, it is important that the use of sorption refrigerators will be strongly stimulated by the future spread of energy-cogeneration systems (sources of combined production of electricity and heat) and accordingly by the creation of trigeneration sources. Another important factor of operation of a sorption heat engine is a low-temperature heat source that appreciably influences the heat-pump structure from the viewpoint of economy and environmental protection.

Solid-sorbent heat pumps also include hydrogen heat pumps in which metal hydrides are used as sorbents. For hydrogen heat pumps, the enthalpy ΔH changes in the limits from -30 to $+40$ kJ/mole during the cycle when such metal hydrides as LaNi, LaNiAl, LaNiSn, and LaNiMn are used. Hydrogen heat pumps are characterized by the small change in the enthalpy ΔH during the cycle; accordingly, there is a weak dependence of the pressure on temperature (plateau). Hydrogen heat pumps are of high thermodynamic efficiency and ensure a wide range of variation in the temperature; however, they require a high level of service reliability and are relatively expensive.

3. Sorption Solar Refrigerators. A solar refrigerator is a variation of a solid-sorbent heat pump in whose evaporator a temperature lower than the environmental temperature is maintained. Sorption technologies ensure energy saving and environmental protection when refrigerators are created with the use of alternative sources of energy, primarily of solar energy.

Figure 12 gives a diagram of a solid-sorbent refrigerator developed at the Heat and Mass Transfer Institute of the National Academy of Sciences of Belarus; in this refrigerator, solar energy is used for production of cold and heat. By day, cold and heat are produced using solar energy. Electric energy is used for production of cold at night. The solar refrigerator is capable of heating water (1 kW of heat) and cooling air in the refrigerator chamber (200 W of cold). The refrigerator consists of two sorbent-filled adsorbers and a thermal-regulation system on heat pipes. Solar energy heats the heat-pipe evaporator, and the heated steam is alternately used for desorption of one adsorber or the other. Water in the moderate-temperature circuit and ammonia in the low-temperature circuit are used as working fluids in the heat pipes. The thermal-regulation system in heat pipes makes it possible to do without mechanical pumps. The refrigerator weight does not exceed 20 kg.

A substantial component of a solar refrigerator is a two-phase thermal-regulation system. Two modifications of a solar refrigerator have been developed. The first refrigerator has a solar collector constantly focused on the evaporator of a vapor-dynamic thermosyphon.

Figure 13 shows a diagram of a prototype of solar refrigerator in which a miniature gas burner is used as an energy source alternative to the sun. The basic components of the solar refrigerator are a solar collector, sorbent-filled vessels, an evaporator, and a condenser. The structure of the prototype of a solar refrigerator is based on glass collectors, i.e., commercially available solar-radiation accumulators. Inside the collector, the thermosyphon's evaporator absorbs solar energy from the local solar collector in the bulb. The structure of the solar refrigerator is convenient for operation and makes it possible to use different numbers of vacuum bulbs depending on the heat load.

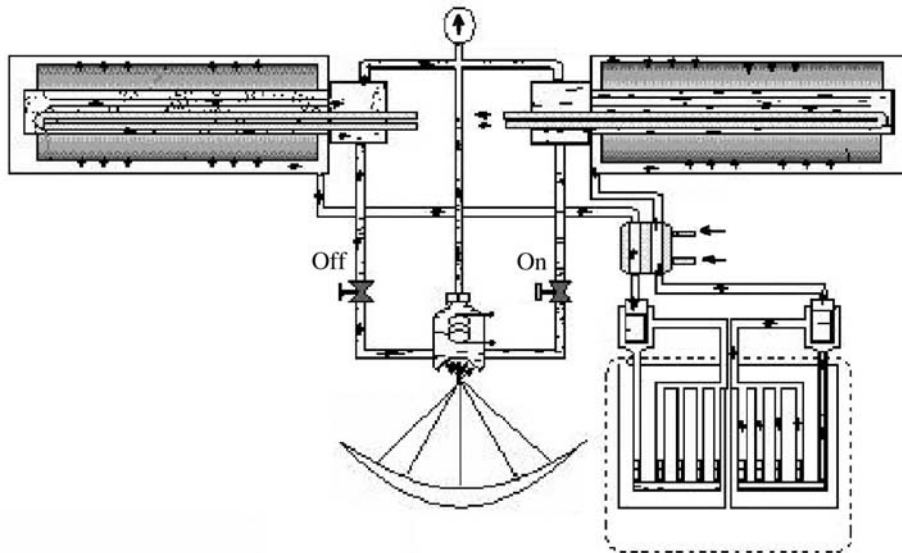

Fig. 12. Sorption refrigerator on heat pipes, operated by solar and electric energy with a solar-radiation collector.

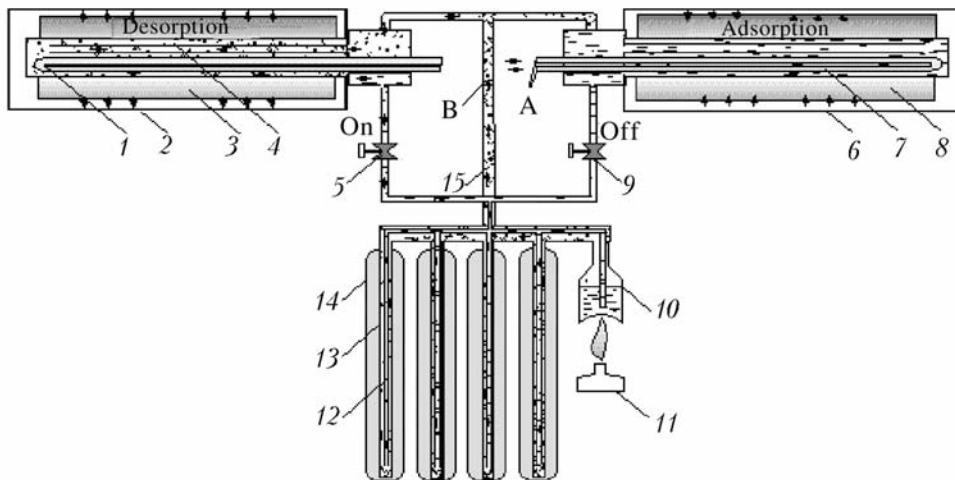

Fig. 13. Schematic diagram of the two-adsorber solar refrigerator on heat pipes with vacuum bulbs — solar-radiation detectors: 1 and 7) heat exchangers; 2 and 6) adsorbers; 3 and 8) sorbent; 4) vapor channel in the sorbent; 5 and 9) liquid-type heat exchangers; 10 and 13) thermosyphon evaporators; 11) gas burner; 12) thermosyphon liquid channel; 14) vacuum glass bulbs; 15) vapor channel; A, inlet of the cooling water; B, vapor flow from the evaporator to the condenser.

The original part of the solar refrigerator has the structure of a thermal-regulation system (thermosyphon system with collectors/evaporators and collectors/condensers) and valves for switching the liquid flow from the condenser to the evaporator. The thermal-regulation system is used for periodic heating and cooling of the sorbent-filled vessels.

Conclusions. The use of sorption heat pumps and refrigerators offers wide opportunities for energy savings in power engineering, industry, and housing facilities and public utilities. The main heat sources for these heat engines are the heat of combustion of natural gas, waste heat of enterprises and heat-supply systems, and geothermal waters and groundwater. As the source of low-temperature heat in the heat-pump's evaporator, one uses the heat of the ambient and exhaust air, soil, natural water reservoirs, groundwater, sewer drains, etc.

NOTATION

COA, efficiency of the heat pump for heating, COA_R, efficiency of the resorption heat pump for heating; COP, cooling performance of a refrigerating machine; COPA, efficiency of the heat pump for heating and cooling; COP_{wth r}, efficiency of the refrigerating cycle without regeneration; c_{liq} , specific heat of the liquid; c_v , specific heat of the vapor; c_p , specific heat; $c_{p,a}$, specific heat of ammonia; G, gas; ΔH , enthalpy gradient; ΔH_c , change in the enthalpy of the condenser; ΔH_e , change in the enthalpy of the evaporator; ΔH_R , change in the enthalpy of the sorbent-filled vessel; ΔH_{R1} , change in the enthalpy of adsorber S₁; ΔH_{R2} , change in the enthalpy of adsorber S₂; h_{ads} , adsorption enthalpy; L, liquid; L_v , latent evaporation heat; m , sorbent mass; Δm , change in the sorbent mass; m_{liq} , liquid mass; P , pressure; p_{sat} , saturation pressure; ΔQ , change in the thermal energy; ΔQE_{ev} , change in the thermal energy in the evaporator in evaporation; Q_1 , heat from the thermostat with a high temperature T_1 ; Q_2 , heat taken by the thermostat with a low temperature T_2 ; q_{ads} , sorption heat; q^* , mass of the adsorbate in the sorbent; r , radius; r^* , latent heat of vaporization; r_g , regeneration coefficient; S, adsorber; S_{ads} , adsorption entropy; T , temperature; ΔT , temperature gradient; T_1 , high temperature in thermostat 1; T_2 , low temperature in thermostat 2; T_c , intermediate temperature in the heat-pump's evaporator; T_e , low temperature in the heat-pump's evaporator; T_g , high temperature in the heat-pump's thermostat; T_{ev} , evaporator temperature; T_{eff} , effective temperature; T_h , heater temperature; t , time; t_{cycle} , cycle time; V , sorbent volume; W , power; W_{sp} , specific power; w , number of gas molecules; z , coordinate of the axis; η_{refr} , efficiency of the heat pump (cooling performance); η_{heat} , efficiency of the heat pump in heating; $\eta_{t,p}$, coefficient of change in the thermal potential; ρ_{liq} , liquid density. Subscripts and superscripts: a, ammonia; c, condenser; e, evaporator; eff, effective; g, external source (gas); R, reactor; SCP, specific cooling power; s, sorbent; ads, adsorption; wth r, without regeneration; liq, liquid; heat, heating; sat, saturation; v, vapor; t.p, temperature potential; t, tube; sp, specific; refr, refrigerating, cooling; cycle, cycle.

REFERENCES

1. F. Meunier, Sorption contribution to climate change mitigation, in: *Proc. Int. Conf. Sorption Heat Pumps*, 24–27 September, 2002, Shanghai (2002), pp. 1–9.
2. Yu. I. Aristov, Certain environmental and economical aspects of using adsorption thermal facilities in Russia, *Khim. Ustoich. Razvit.*, **12**, 751–755 (2004).
3. L. L. Vasiliev, L. E. Kanonchik, and A. A. Antukh, Contemporary thermodynamic cycles in power engineering — a means of decreasing ejections of carbon dioxide into the atmosphere and increasing the efficiency of electric power stations, *Énergoéffektivnost'*, No. 11, 16–18 (2002).
4. L. L. Vasiliev, D. A. Mishkinis, A. A. Antukh, and L. L. Vasiliev Jr., Solar–gas solid sorption heat pump, in: *Proc. Int. Sorption Heat Pump Conf. (ISHPC)*, 24–26 March, 1999, Munich, Germany (1999), pp. 117–122.
5. L. L. Vasiliev, D. Nikanpour, A. A. Antukh, K. Snelson, L. L. Vasiliev Jr., and A. Lebru, Multisalt-carbon chemical cooler for space applications, in: *Proc. Int. Sorption Heat Pump Conf. (ISHPC)*, 24–26 March, 1999, Munich, Germany (1999), pp. 579–583.
6. G. Restuccia, A. Freni, and G. Cacciola, Adsorption beds of zeolite on aluminum sheets, in: *Proc. Int. Sorption Heat Pump Conf. (ISHPC)*, 24–26 March, 1999, Munich, Germany (1999), pp. 343–347.
7. L. L. Vasiliev and S. L. Vaaz, *Freezing and Heating of Ground by Cooling Devices* [in Russian], Nauka i Tekhnika, Minsk (1986), 192 p.
8. F. Meunier (Ed.), *Proceedings of Solid Sorption Refrigeration Symposium*, 18–20 November, 1992, Paris (1992).
9. D. Nikanpour and S. Hosatte (Eds.), Towards sustainable technologies, in: *Proc. Absorption Heat Pump Conf.*, 17–20 September, 1996, Montreal, Canada (1996).
10. C. Schweigler, S. Summerer, H-M. Hellmann, and F. Ziegler (Eds.), *Proc. Int. Sorption Heat Pump Conf. (ISHPC 1999)*, 24–26 March, 1999, Munich, Germany (1999).
11. Ruzhu Wang, Zhen Lu, Wen Wang, and Xinghua Huang (Eds.), *Proc. Int. Sorption Heat Pump Conf. (ISHPC 2002)*, Science Press New York Ltd, 24–27 September, 2002, Shanghai, China, 2002.

12. Yu. I. Aristov, L. L. Vasil'ev, and V. E. Nakoryakov, Chemical and sorption heat engines: state of the art and development prospects, *Inzh.-Fiz. Zh.*, **81**, No. 1, 19–48 (2008).
13. I. Yaron and I. Borde, Working fluids for heat pumps, *VDI-Berichte 539, ORC-HP-Technology*, VDI, Dusseldorf (1984), pp. 145–162.
14. I. Borde, M. Jelinek, and N. Daltrophe, Working fluids for an absorption system based on R124/2-chloro-1,1,1,2-tetrafluoroethane and organic absorbents, *Int. J. Refrigeration*, **20**, No. 4, 256–266 (1996).
15. M. Ishikawa, H. Kayanuma, and N. Isshiki, Absorption heat pump using new organic working absorbents, in: *Proc. Int. Sorption Heat Pump Conf.*, (ISHPC 1999), 24–26 March, 1999, Munich, Germany (1999), pp. 197–204.
16. Y. T. Kang, K. Iizuka, A. Akisawa, and T. Kashiwagi, Experiments on heat transfer additives for NH₃-H₂O solution, in: *Proc. Int. Sorption Heat Pump Conf.*, (ISHPC 1999), 24–26 March, 1999, Munich, Germany (1999), pp. 291–296.
17. F. Ziegler and G. Grossman, Review paper: heat transfer enhancement by additives, *Int. J. Refrigeration*, **19**, No. 5, 301–309 (1996).
18. L. Hoffman and F. Ziegler, Heat and mass transfer enhancement by additives in NH₃-H₂O, in: *Proc. Int. Sorption Heat Pump Conf.*, (ISHPC 1999), 24–26 March, 1999, Munich, Germany (1999), pp. 297–300.
19. K. E. Herold, R. Rademacher, and S. A. Klein, Absorption chillers and heat pumps, CRC Press, Boca Raton, FL (1996).
20. K. Hunold, Kalteerzeugung mit Adsorptionstechnik — Prinzip, Einsatzmöglichkeiten, Vor- und Nachteile, erste Betriebserfahrungen, in: *Wirtschaftliche Wärmenutzung in Industrie und Gewerbe VDI — Berichte 1296*, VDI, Dusseldorf (1997), S. 227–242.
21. Yu. I. Aristov, M. M. Burger, W. Parmon, G. Restuccia, H.-D. Burger, W. Mittelbach, and H.-M. Henning, New working materials for sorption cooling/heating driven by low temperature heat: properties, in: *Proc. Int. Sorption Heat Pump Conf.* (ISHPC 1999), 24–26 March, 1999, Munich, Germany (1999), pp. 247–254.
22. L. L. Vasiliev, N. V. Gulko, and V. M. Khaustov, Solid adsorption refrigerators with active carbon-ethanol and carbon-ethanol pairs, in: *Proc. Solid Sorption Refrigeration Symp.*, 18–20 November, 1992, Paris (1992), pp. 92–99.
23. L. L. Vasiliev, L. E. Kanonchik, V. V. Khrolenok, D. A. Mishkinis, and A. S. Zhuravlyov, Activated carbon ammonia and natural gas adsorption storage, in: *Proc. 23rd Biennial Conf. on Carbon (Carbon'97)*, 18–23 July 1997, *Extended Abstracts and Program*, Vol. I, Adsorption/Reactivity Intercalation, University Park Campus, PennState (1997), pp. 334–335.
24. L. L. Vasiliev and Yu. E. Fraiman, *Thermophysical Properties of Poor Heat Conductors* [in Russian], Nauka i Tekhnika, Minsk (1967), 187 p.
25. L. L. Vasiliev and S. A. Tanaeva, *Thermophysical Properties of Porous Materials* [in Russian], Nauka i Tekhnika, Minsk (1971), 230 p.
26. A. V. Luikov, A. G. Shashkov, L. L. Vasiliev, and Yu. E. Fraiman, Thermal conductivity of porous systems, *Int. J. Heat Mass Transfer*, **11**, 117–140 (1968).
27. N. Mazet, S. Moran, and P. Jolly, Dimensionless analysis of main limitations in solid-gas reactive blocks for solid sorption machines, in: *Proc. Int. Sorption Heat Pump Conf.* (ISHPC 1999), 24–26 March, 1999, Munich, Germany (1999), pp. 337–341.
28. L. L. Vasiliev, D. A. Mishkinis, A. A. Antukh, A. G. Kulakov, and L. L. Vasiliev Jr., Resorption heat pumps, *Appl. Therm. Eng.*, **24**, 1893–1903 (2004).
29. F. Meunier, Adsorption heat pump technology: possibilities and limits, in: *Proc. Int. Sorption Heat Pump Conf.* (ISHPC 1999), 24–26 March, 1999, Munich, Germany (1999), pp. 25–35.
30. L. L. Vasiliev, Use of the Earth's energy with the aid of heat pipes, *Inzh.-Fiz. Zh.*, **59**, No. 3, 488–491 (1990).